

23  
0  
107

平瀨作五郎纂譯

用器圖式  
卷二

中込堂藏版

179  
K/207  
25.2  
5.1

11/2232/4/  
/22



用器

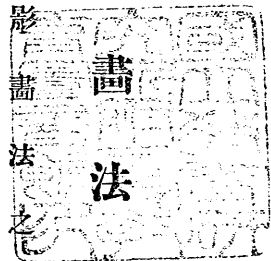

影畫法

法

部

圖

式

卷二

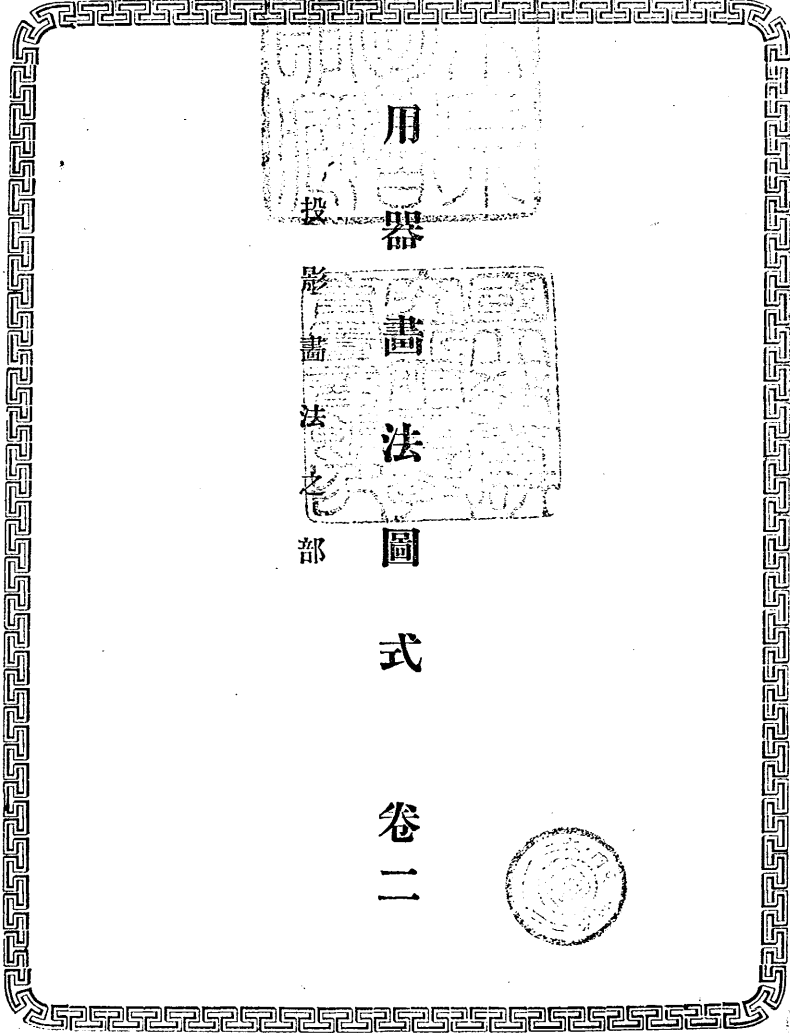

第一圖

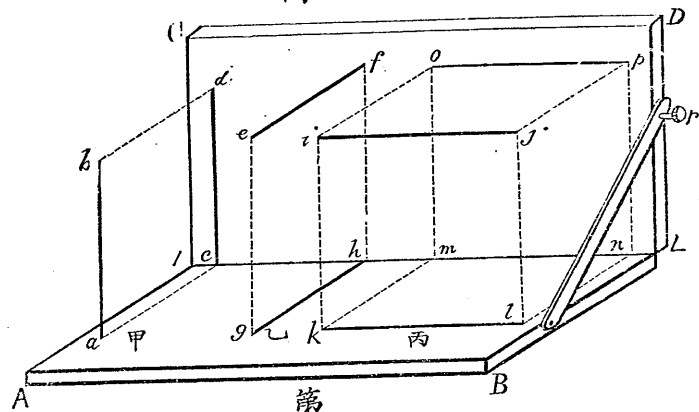

第二圖

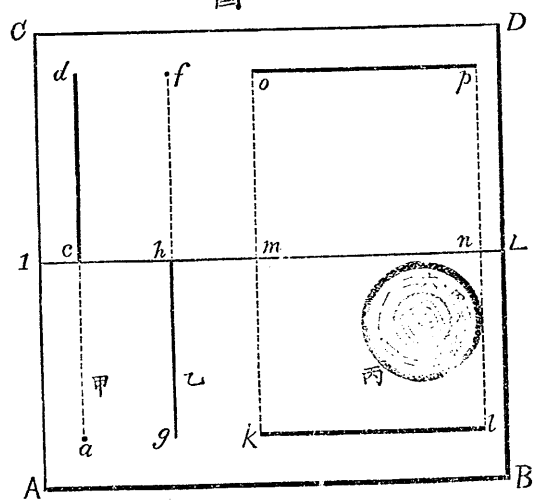

圖三第

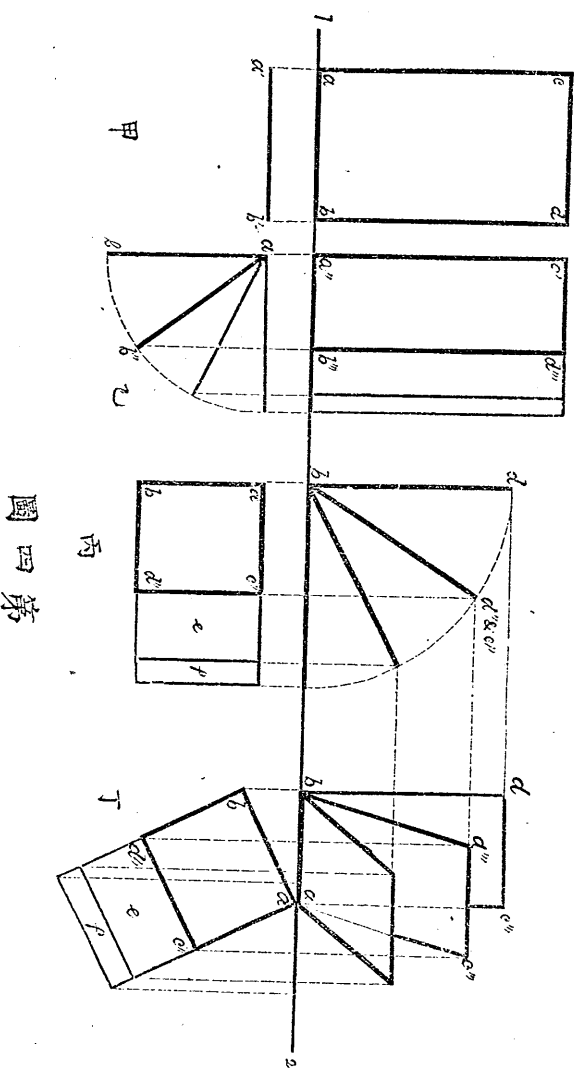
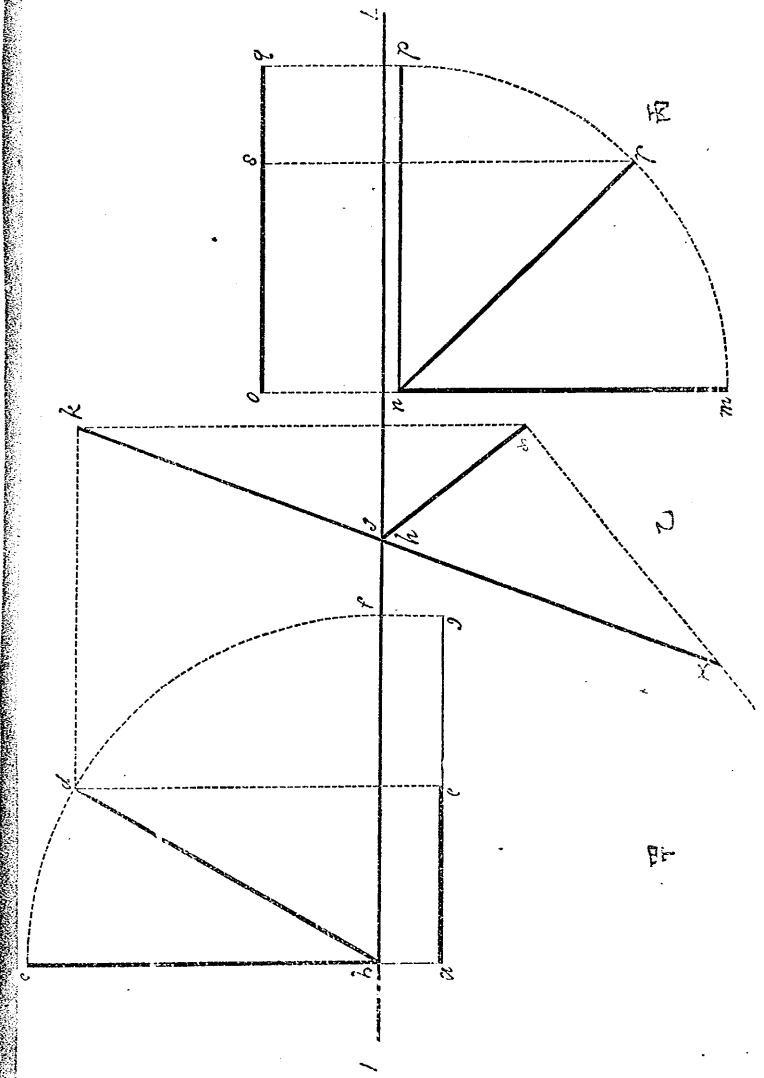

圖四第

圖六第

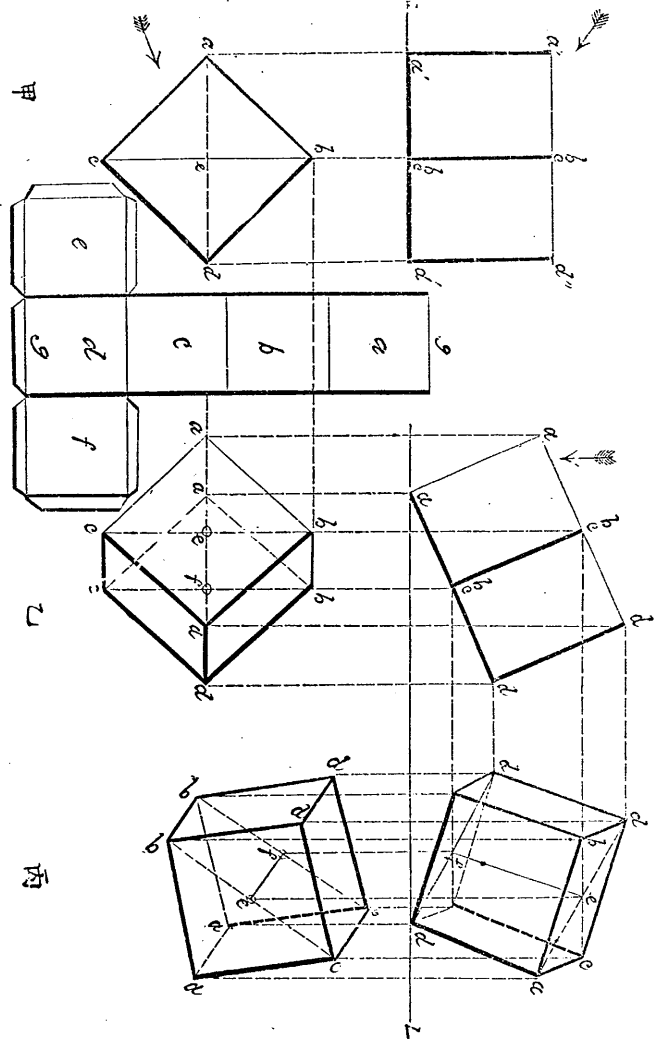

投影五

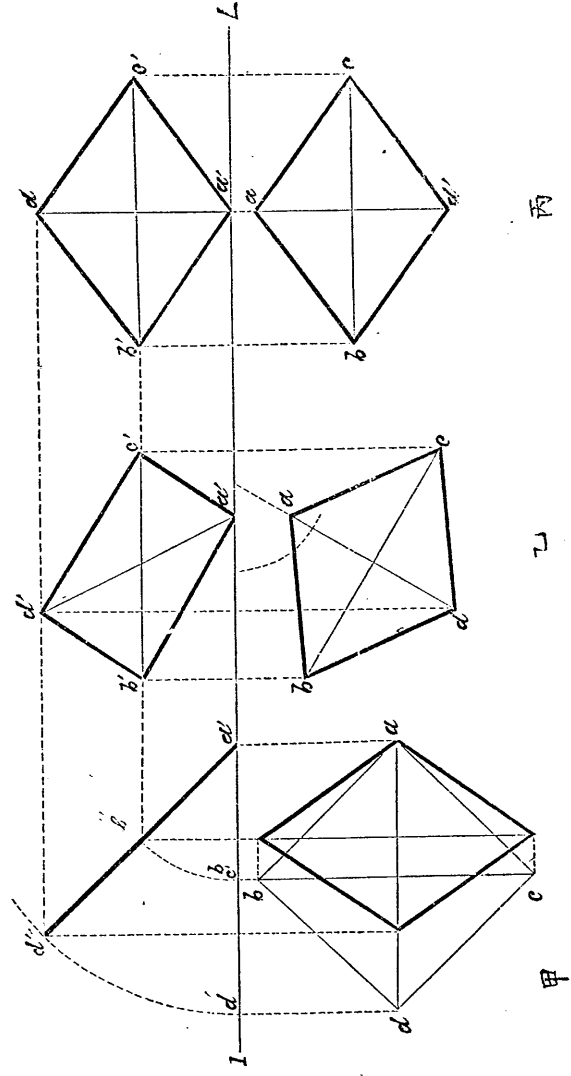

圖五第

圖八第

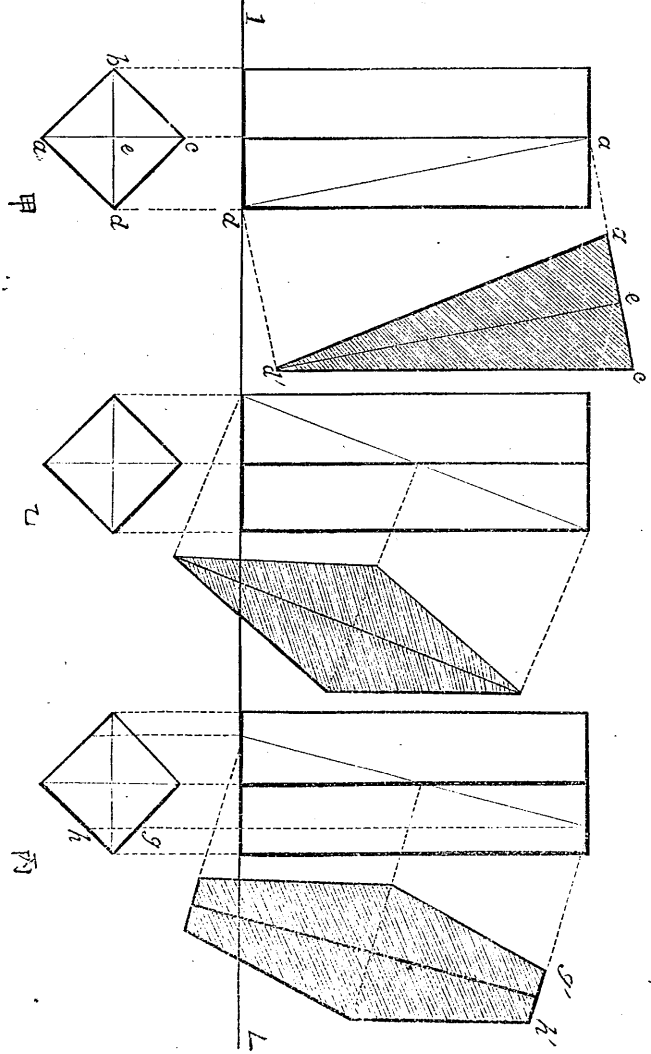

投影六

投影七

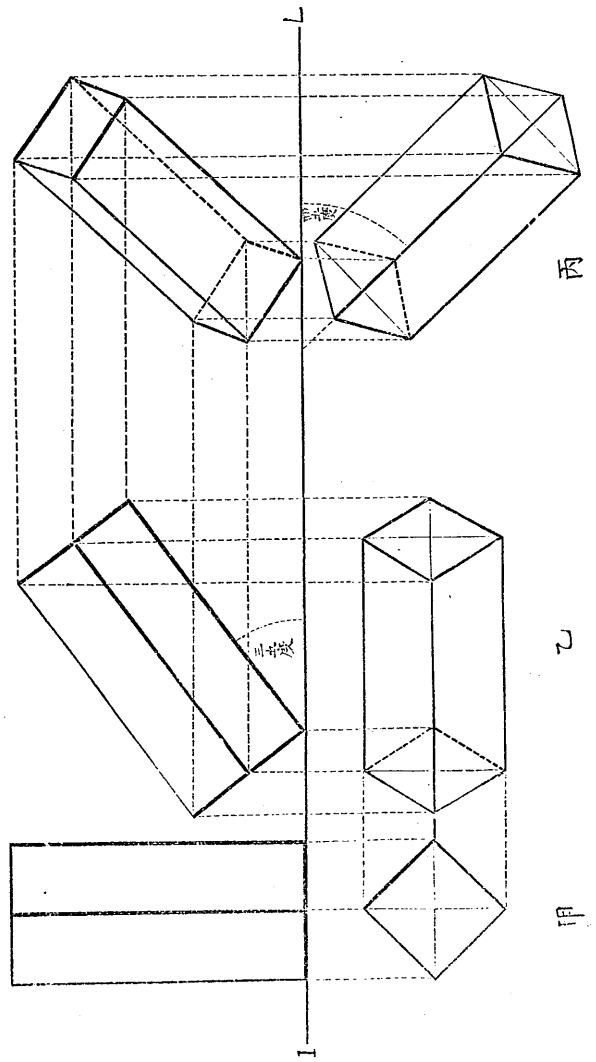

圖七第

圖十第

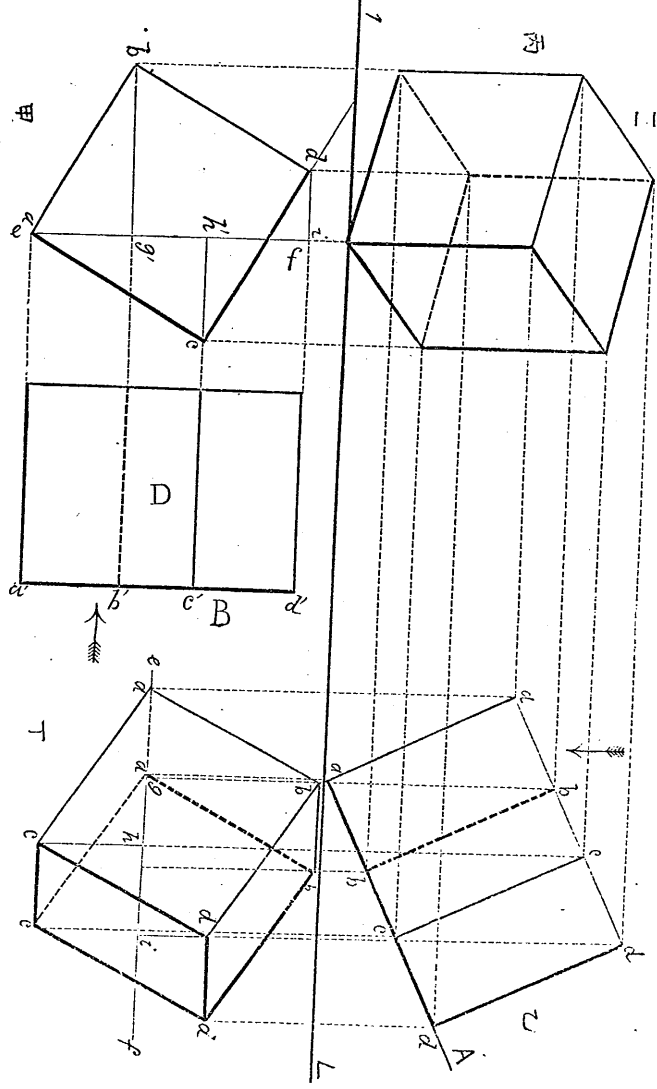

投影八

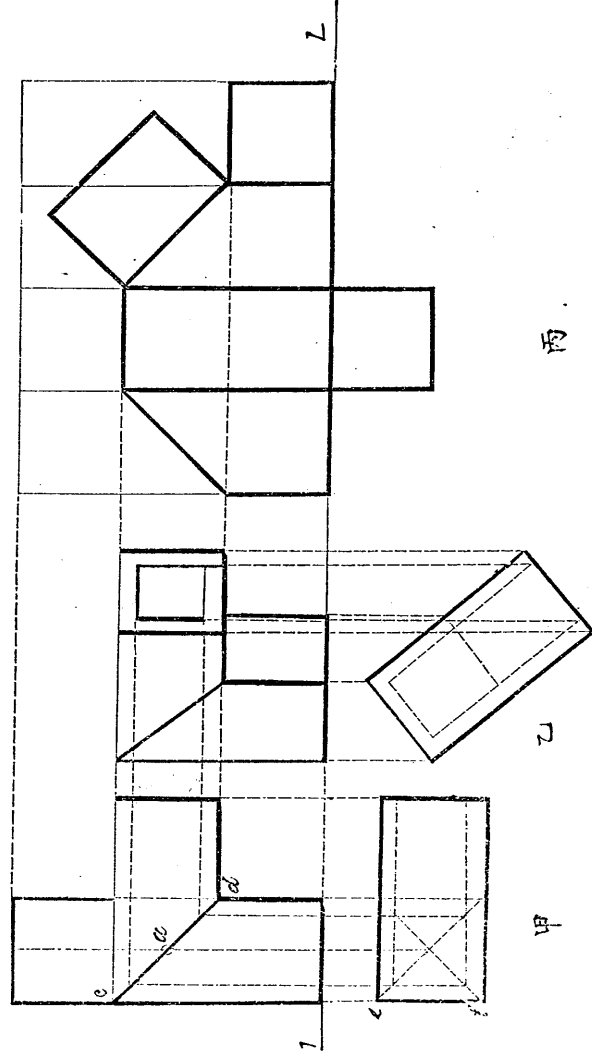

圖九第

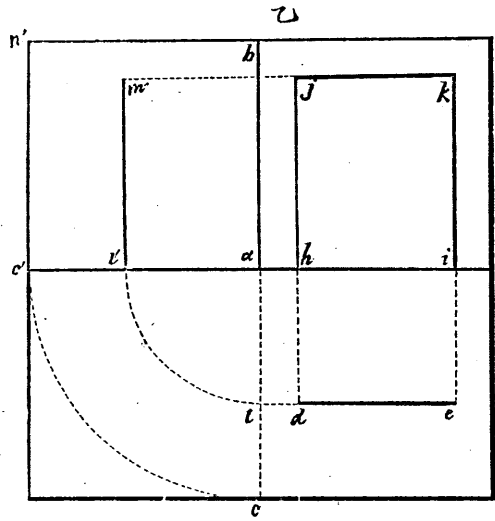
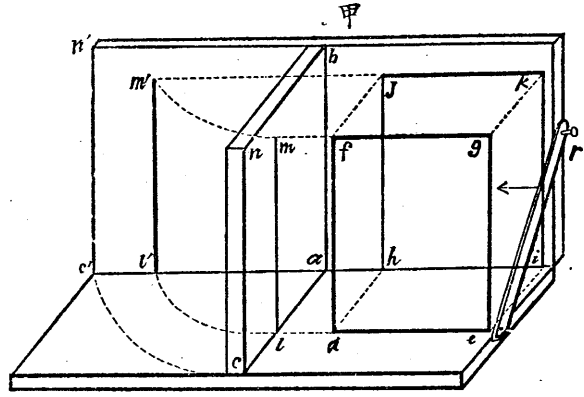

第十二圖

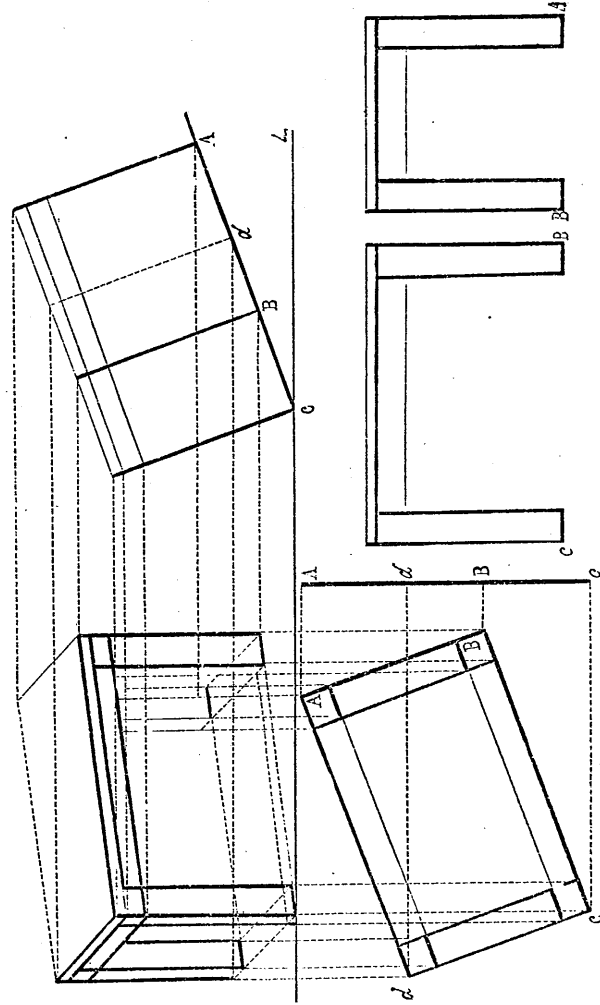

第十圖



圖四十一第

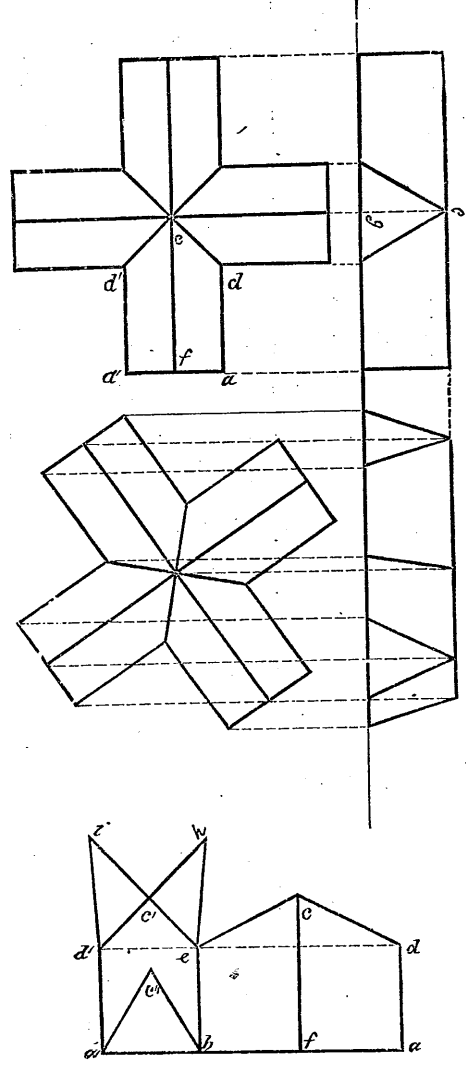

丙

乙

甲

投影法

圖三十第

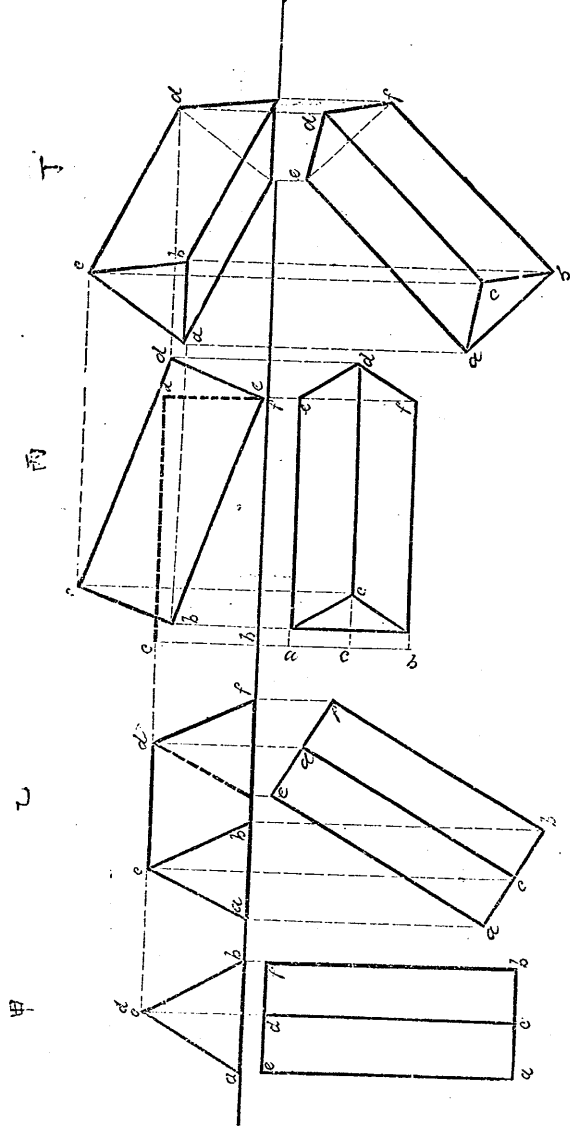

甲

乙

丙

丁

圖六十第

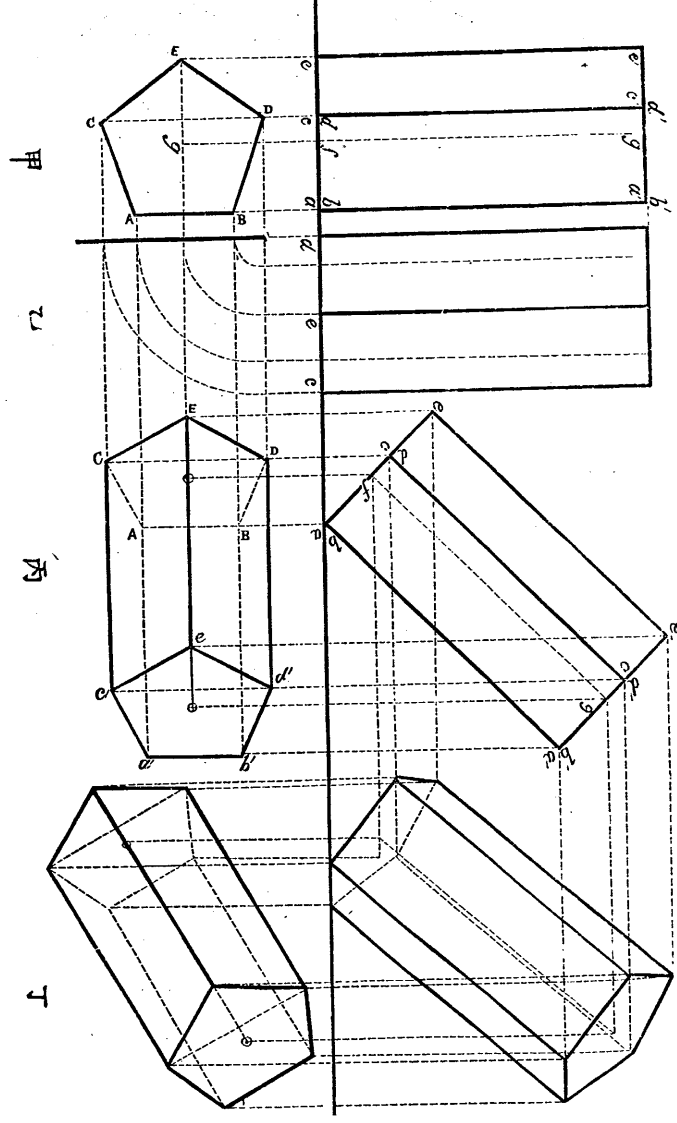

技藝十五  
百六十五

圖五十第

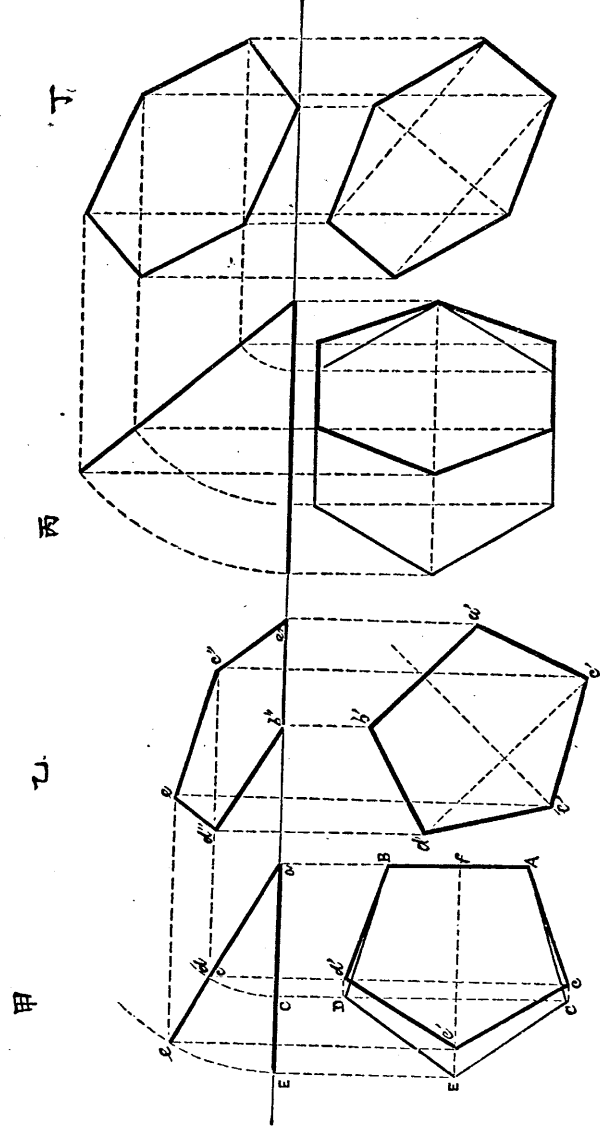

圖八十第

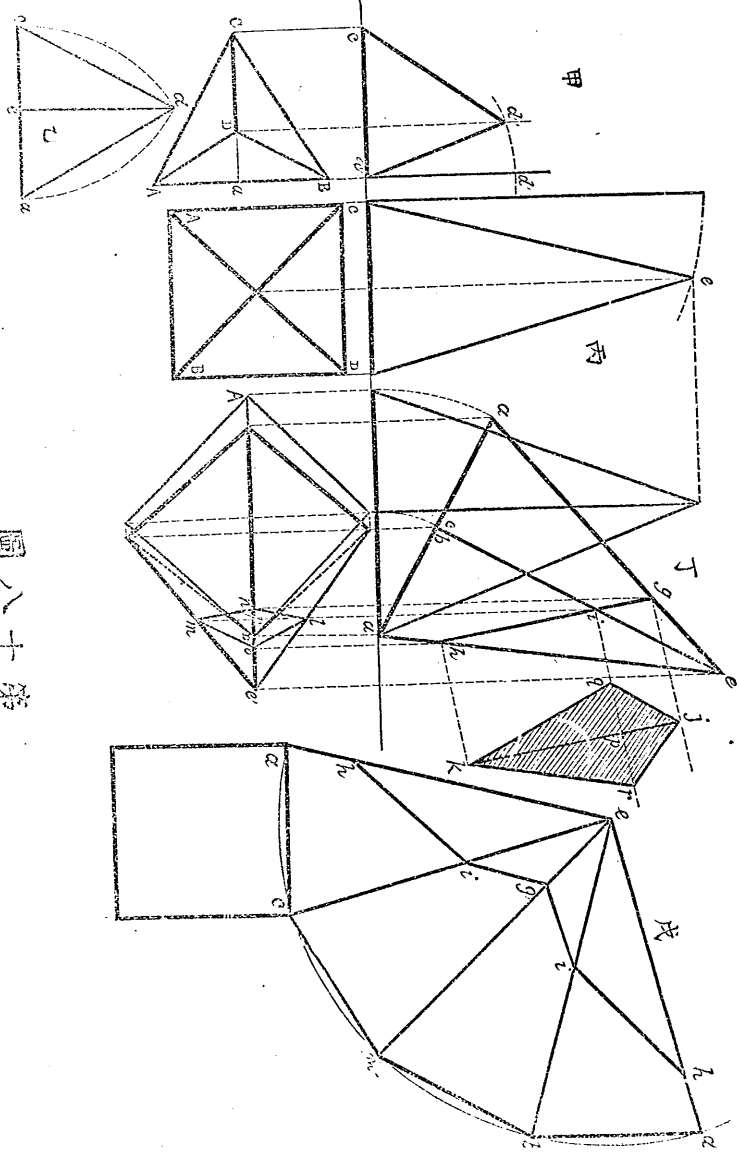

投影十六

投影十六

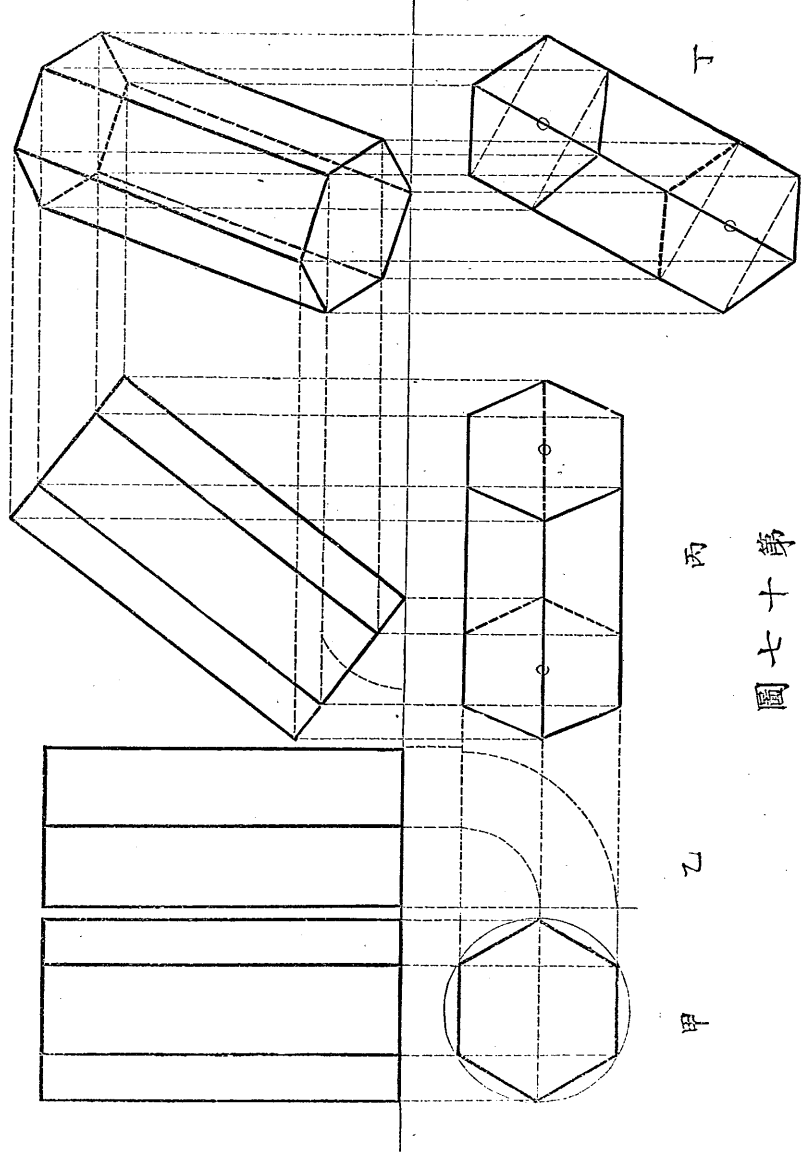

圖七十第

圖十二第

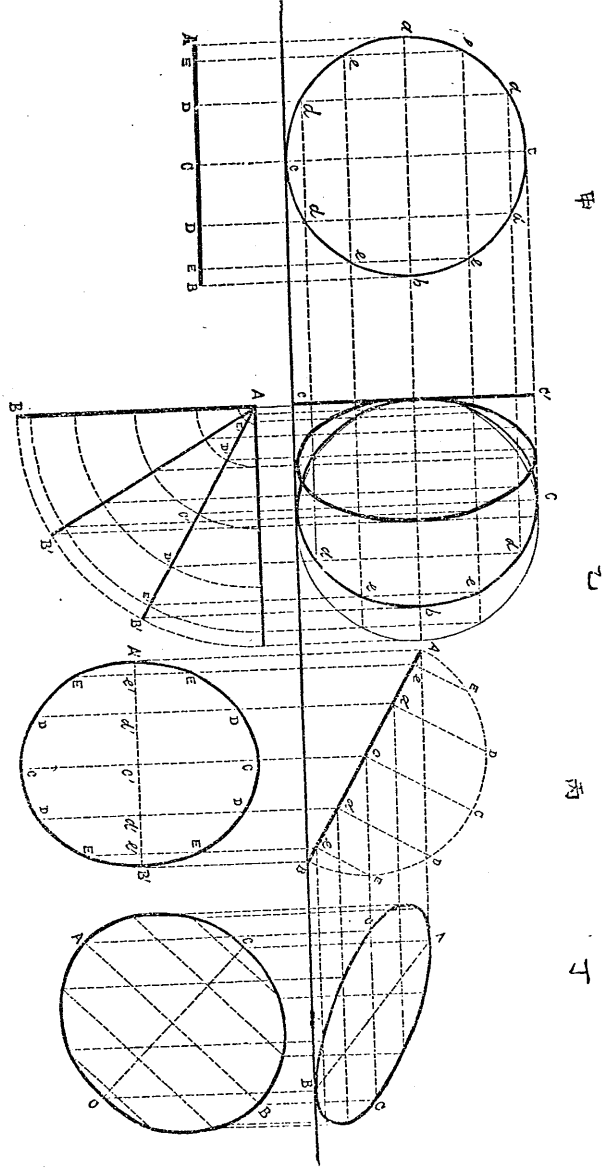

投影十九

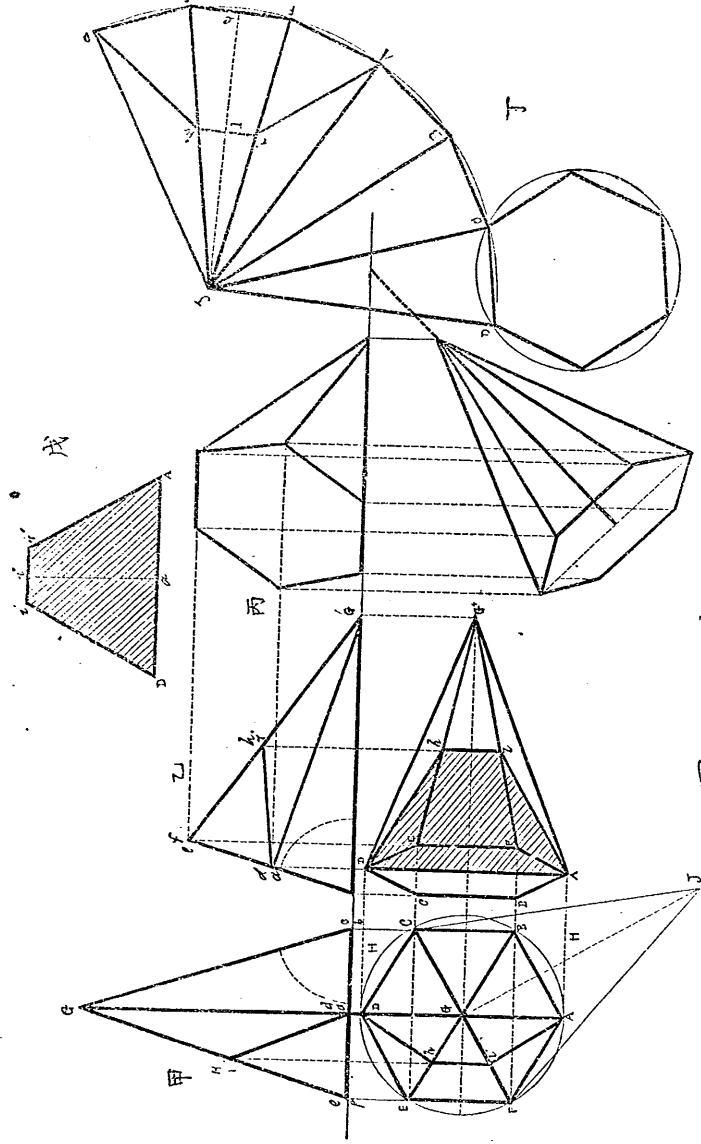

圖九十第

圖二十二第

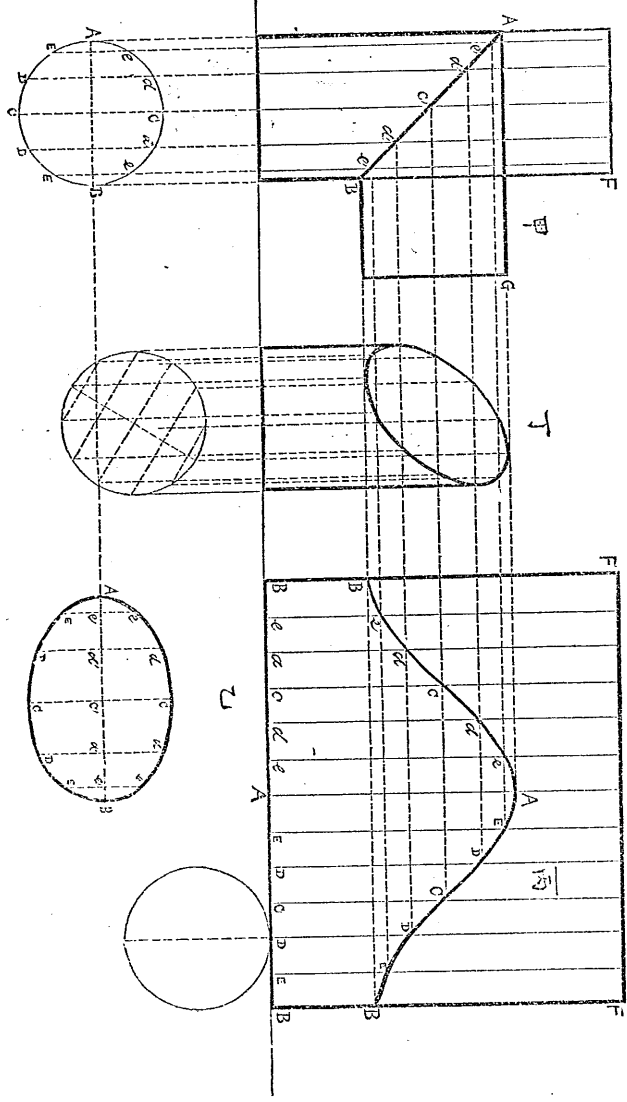

投影法

十一號

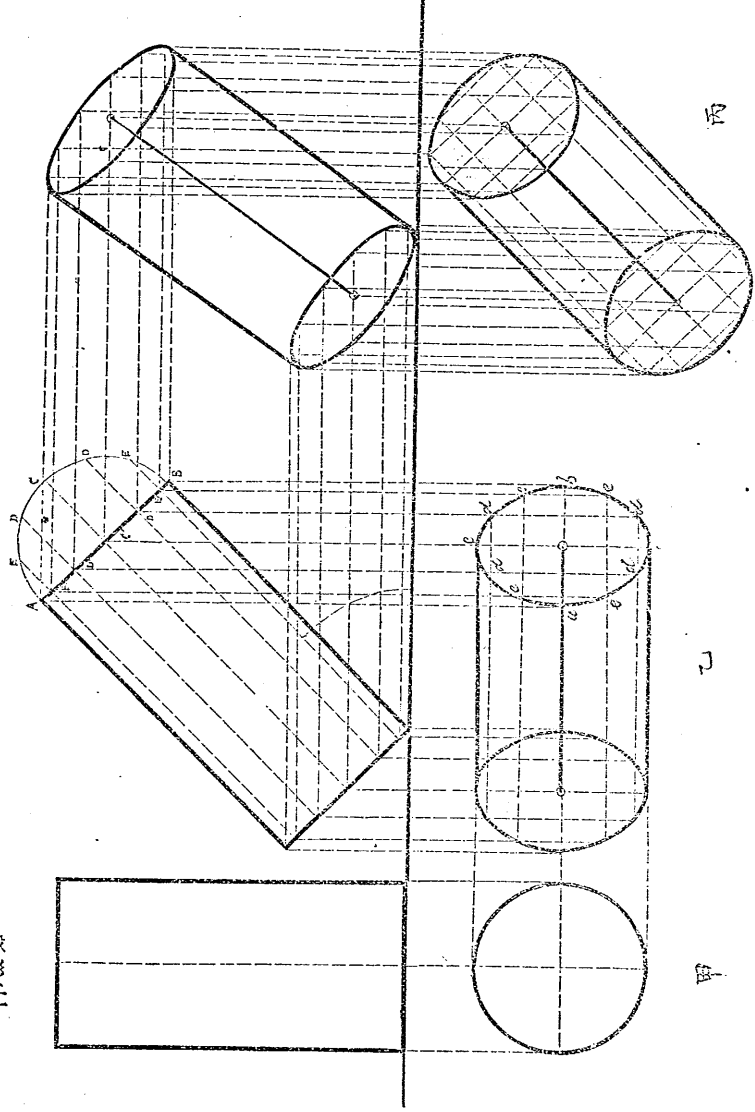

圖一十二第

圖四十二第

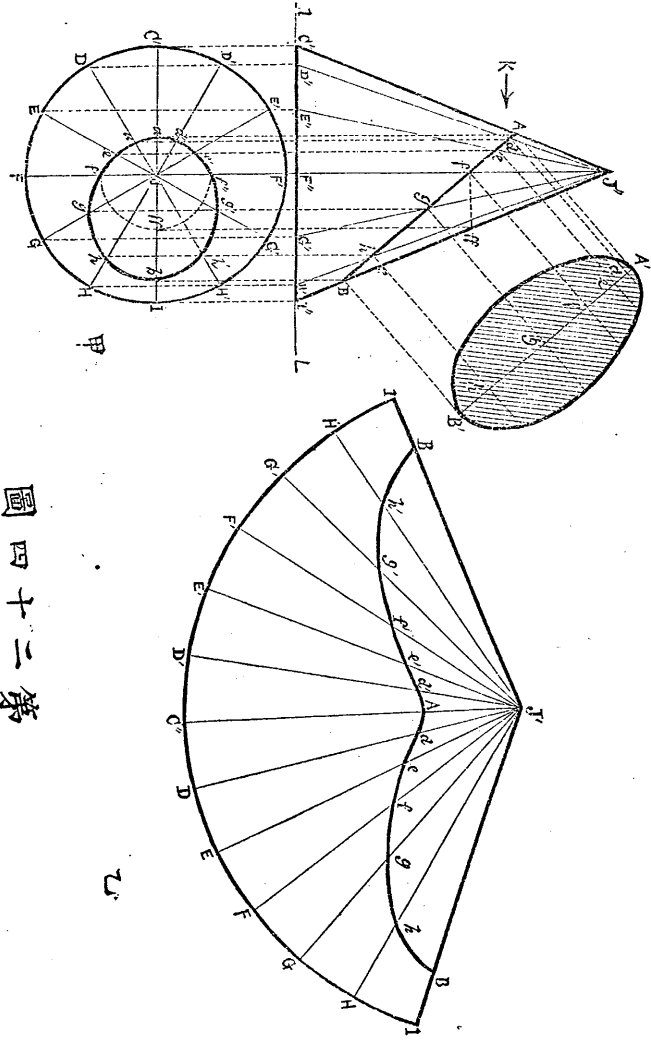

投影三

圖三十二第

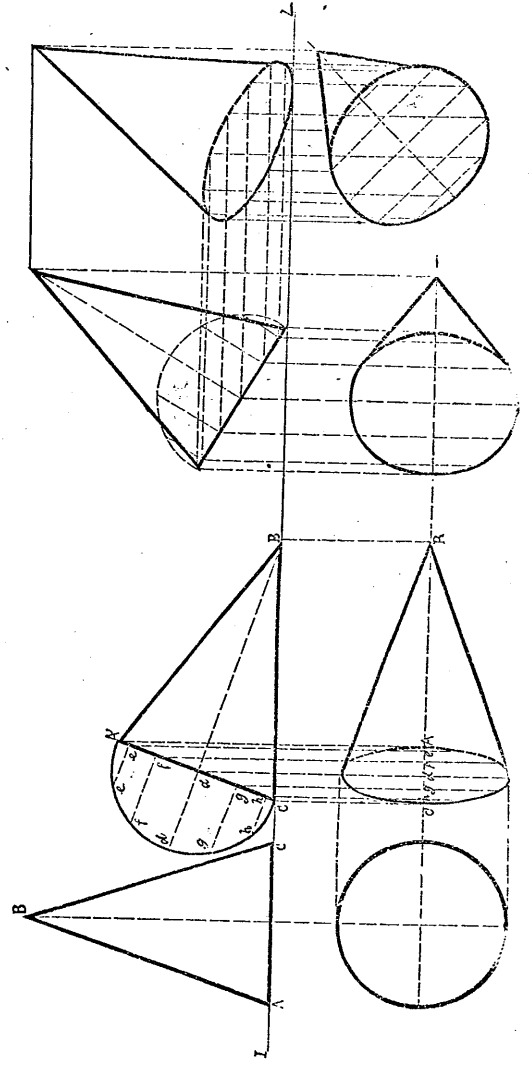

甲 乙 丙 丁

圖三十二第

圖六十二第

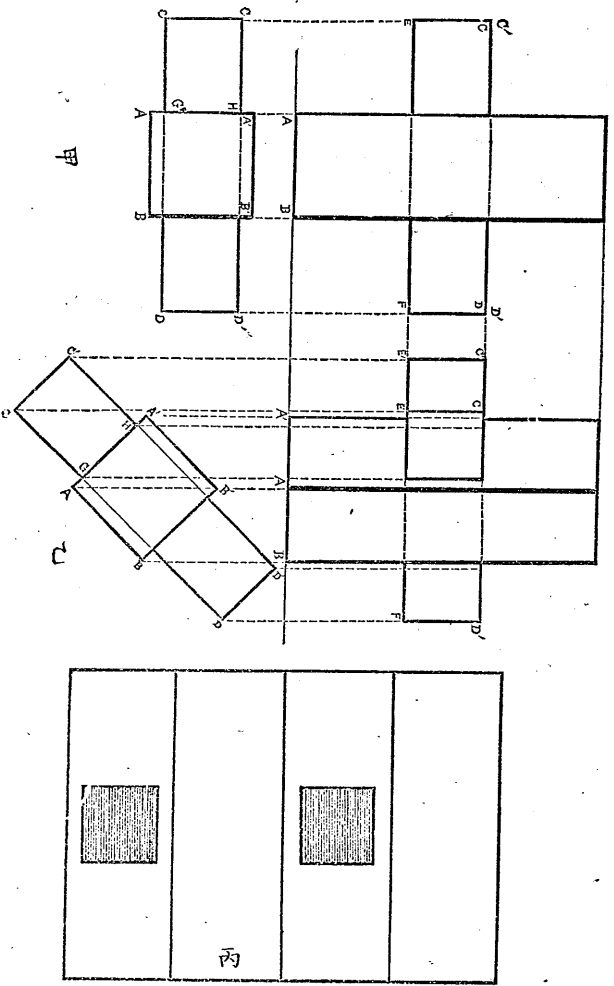

此收錄三十五

五

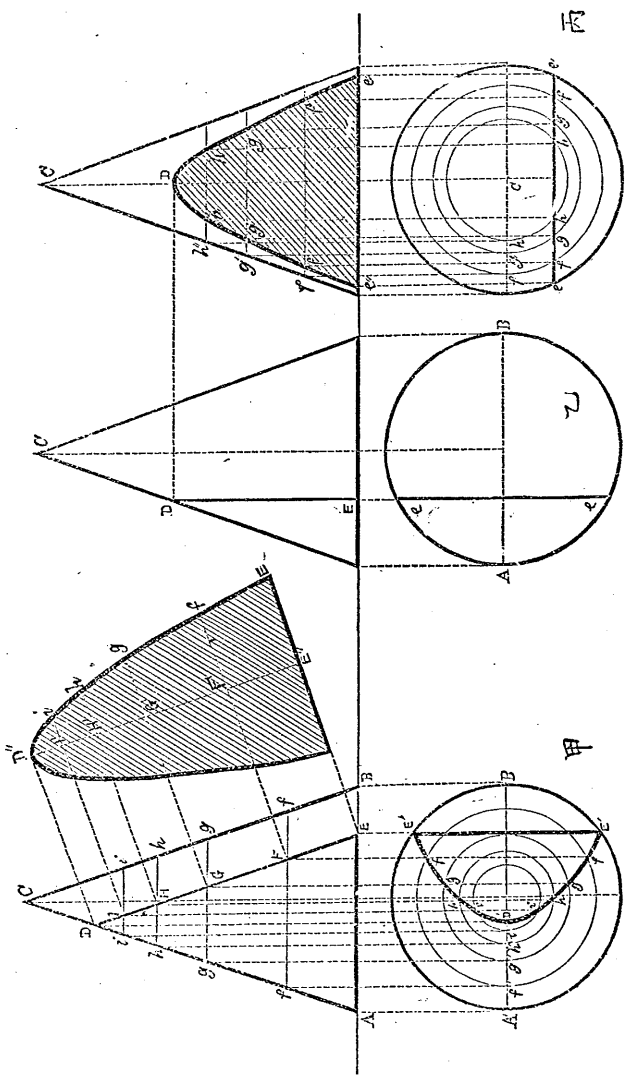

圖五十二第

圖七十二第

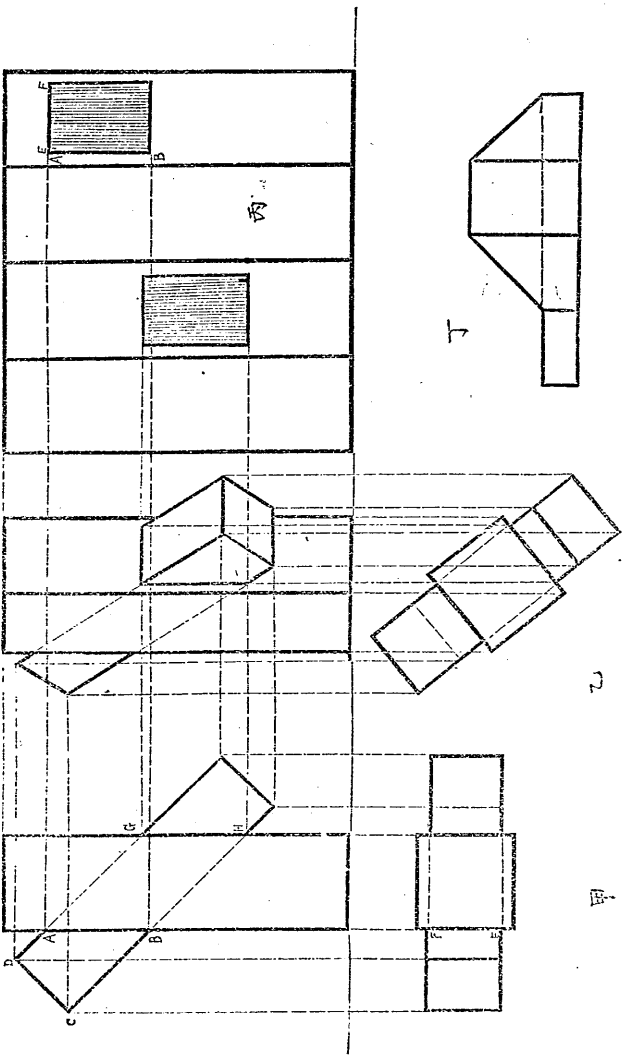

投影法  
卷之六

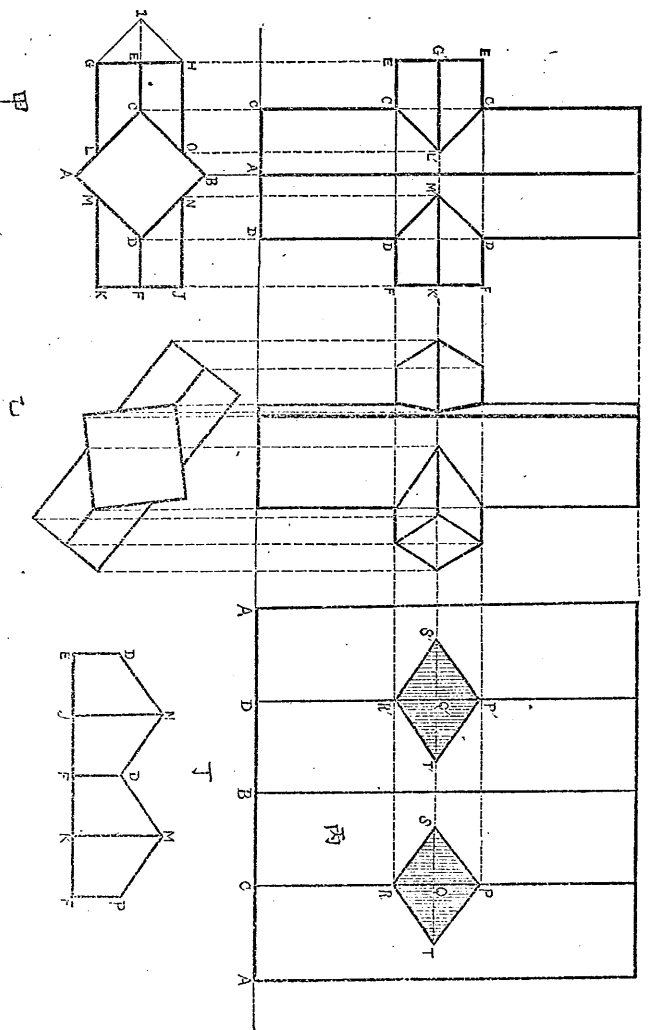

圖八十二第



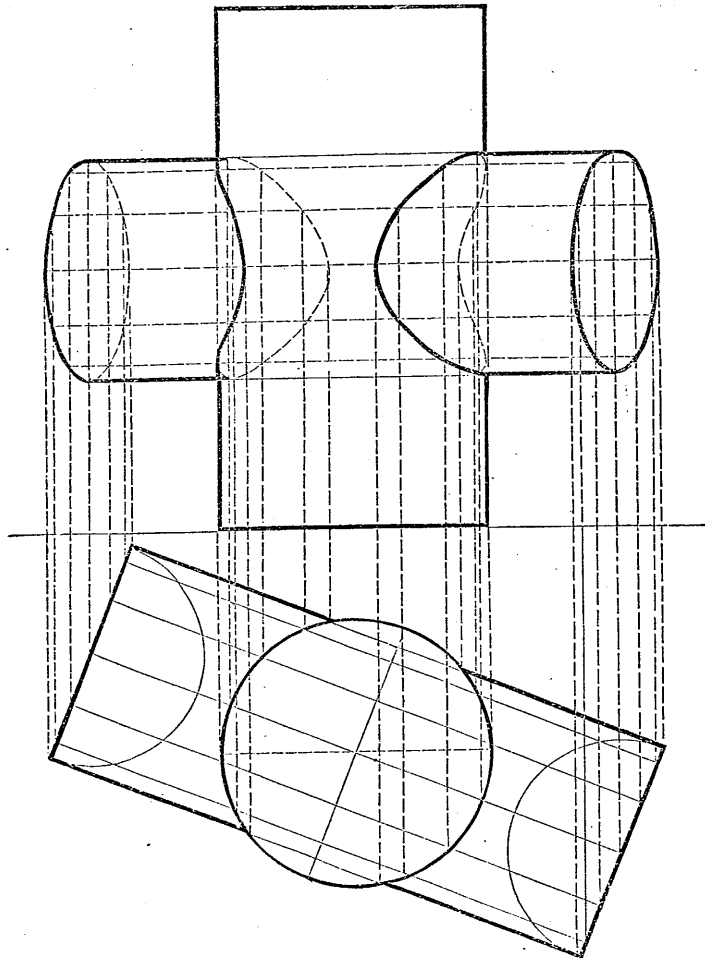

圖十三第

投影二十九  
投影二十八

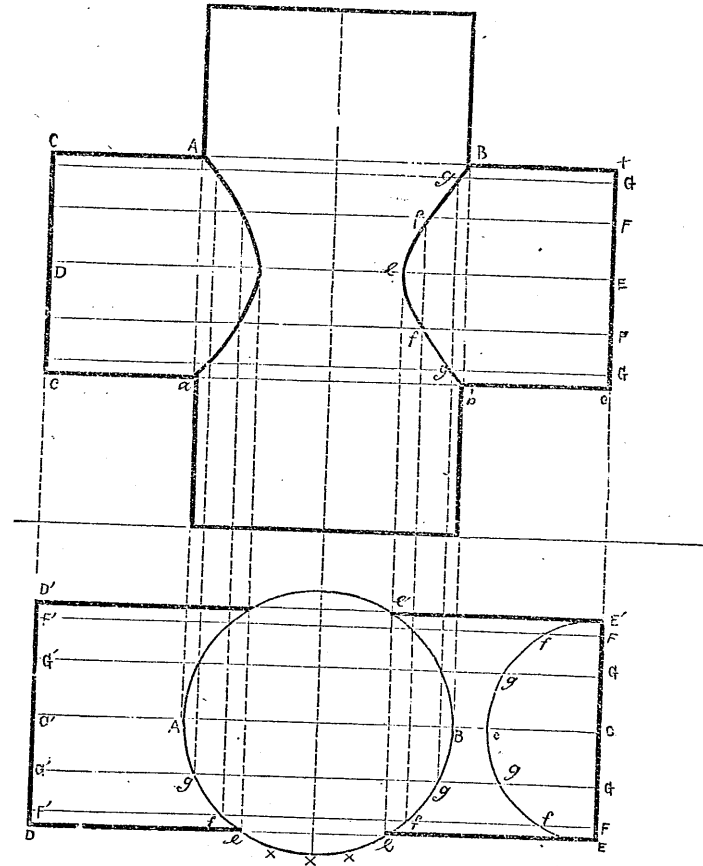

圖九十二第

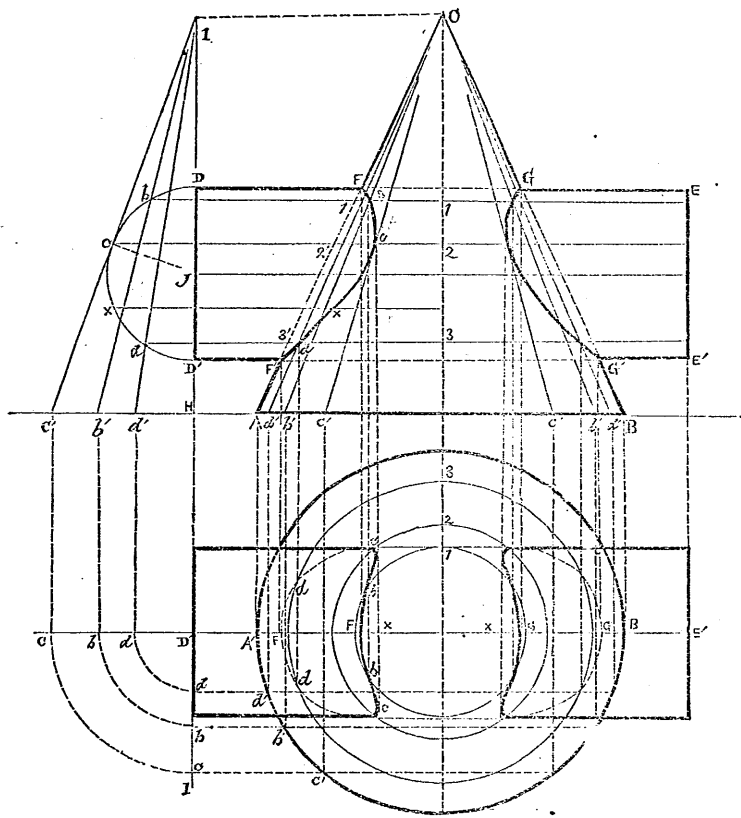

圖二十三第

投影三十一

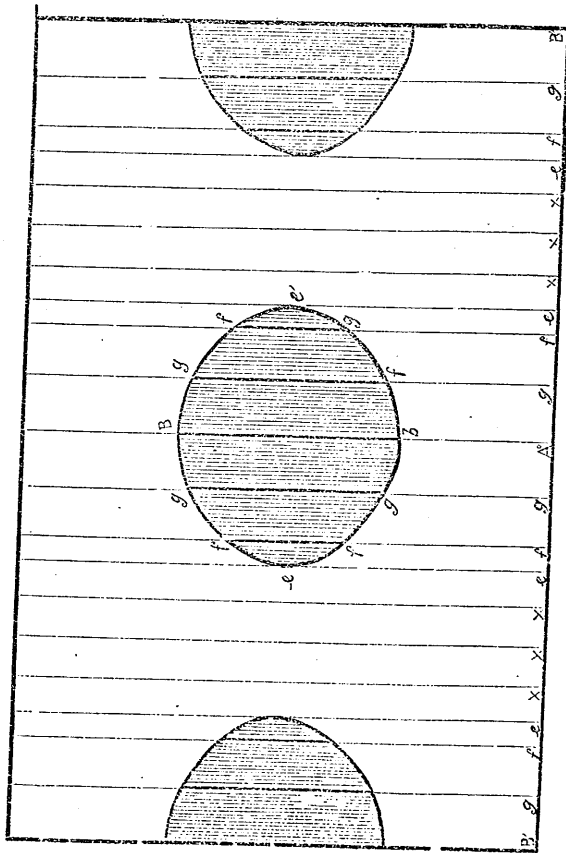
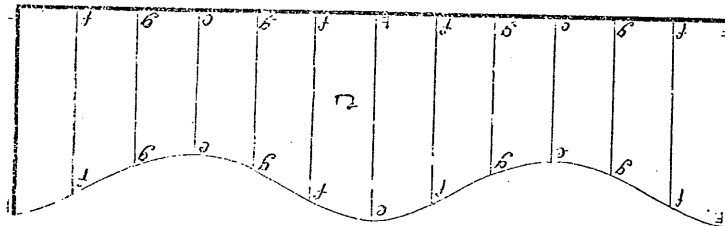

甲

圖一十三第

投影三十

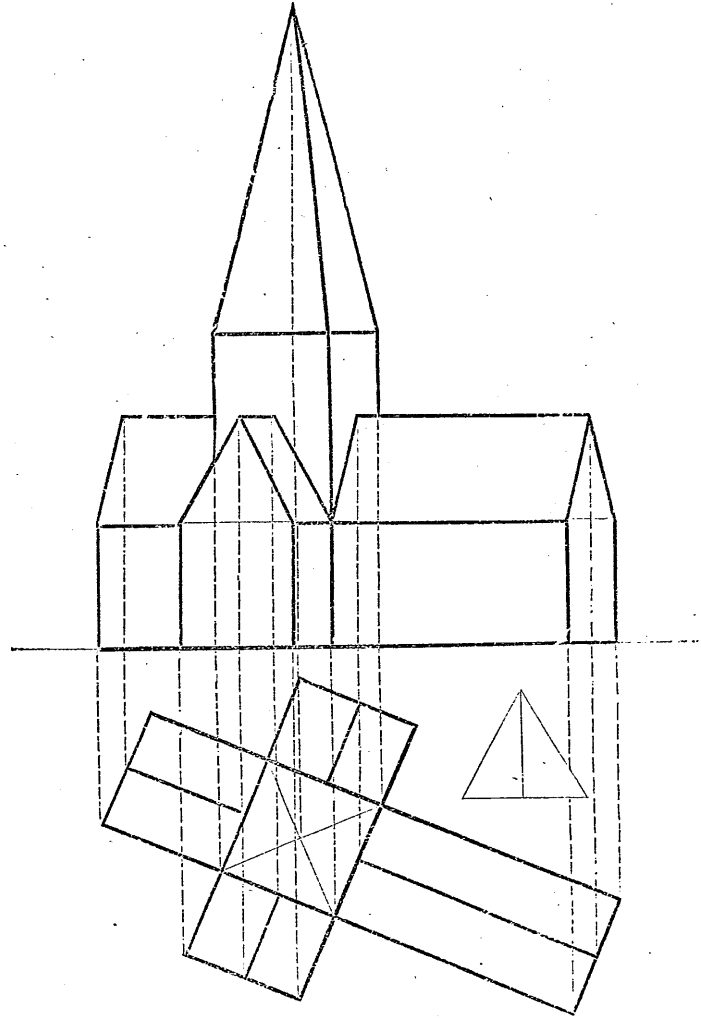

圖四十三第

投影三十二

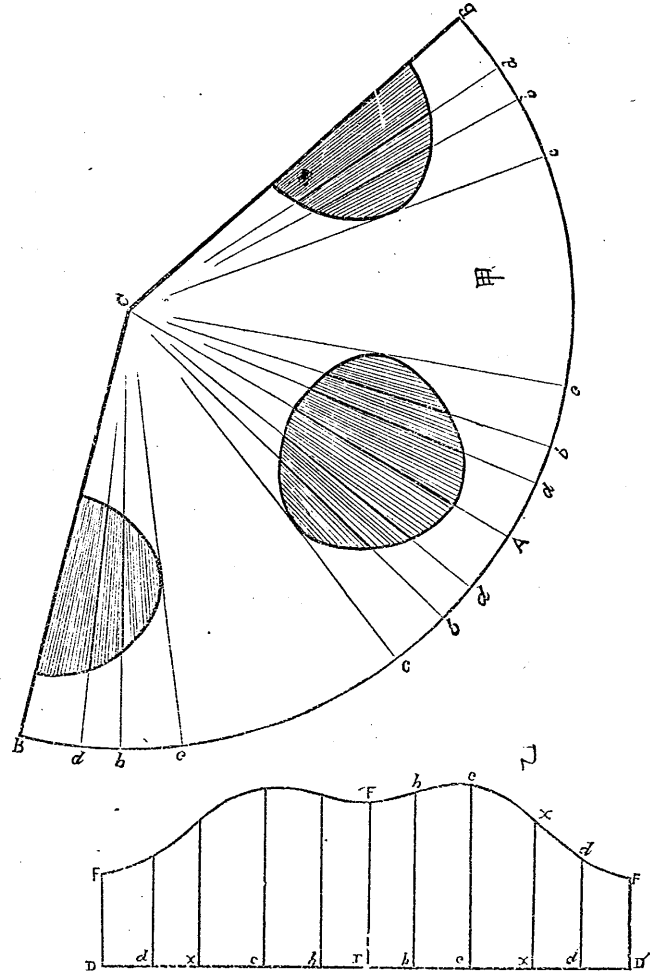

圖三十三第

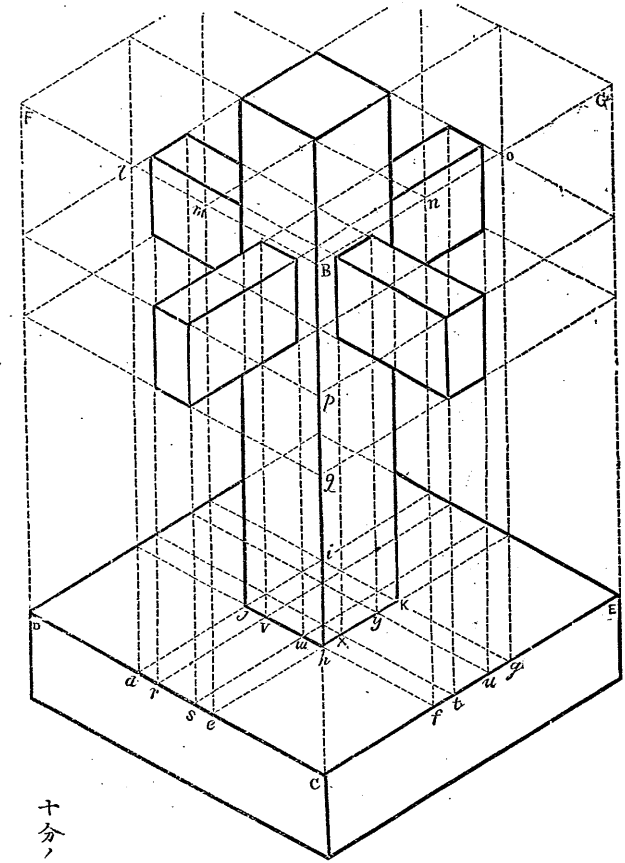

十分之三

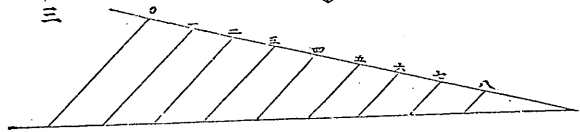

圖六十三第

投影法

圖五十四

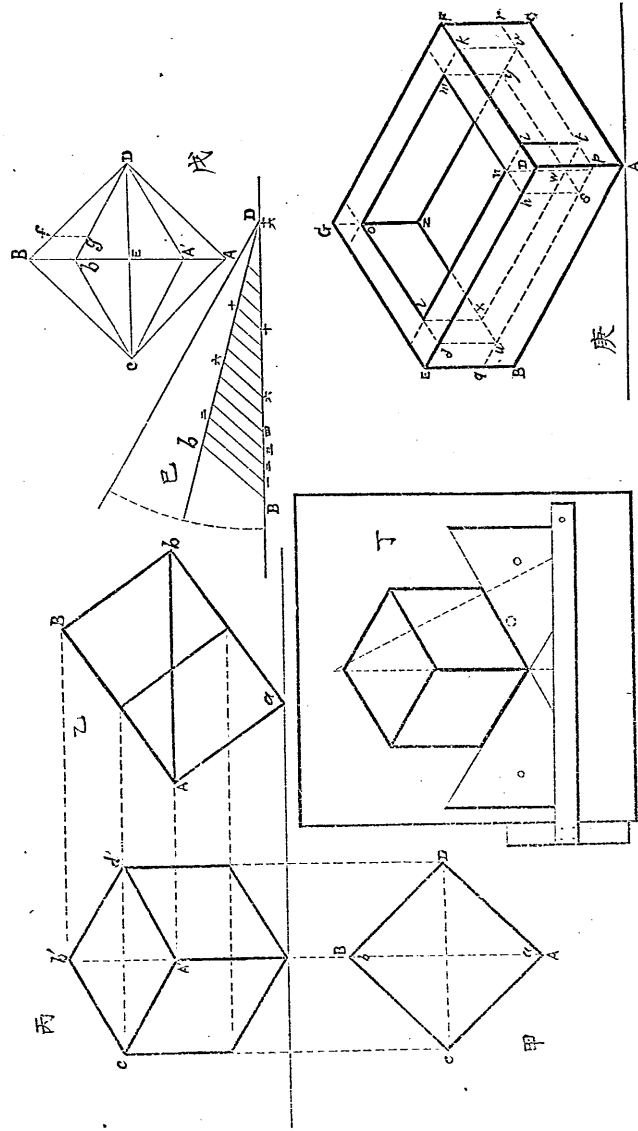

圖五十三第

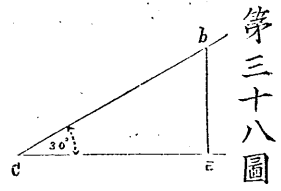

第三十八圖

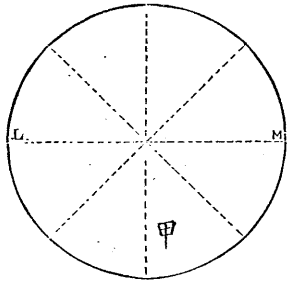

第三十九圖

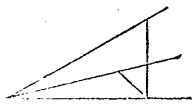
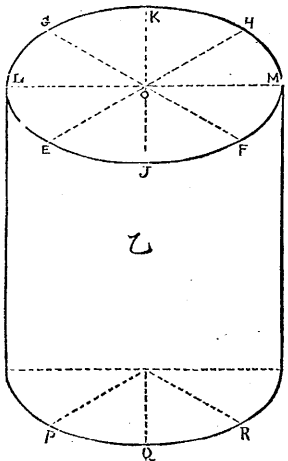

圖十四第

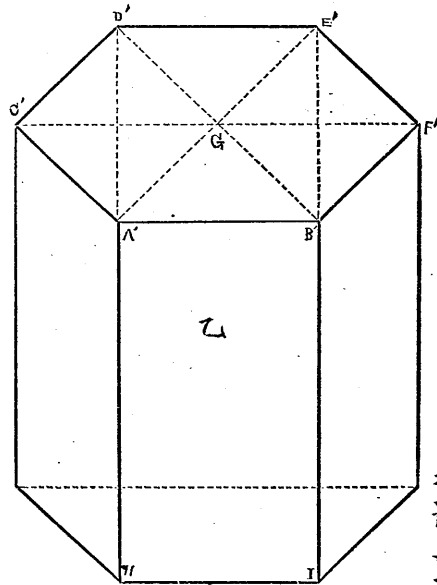
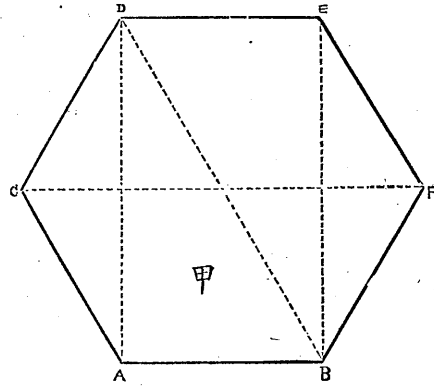

投影三十七  
數影三十六

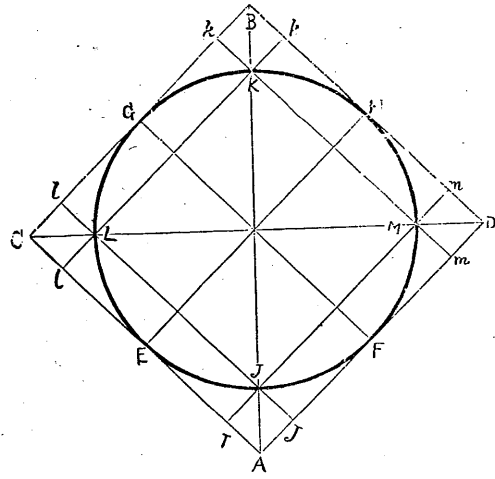

甲

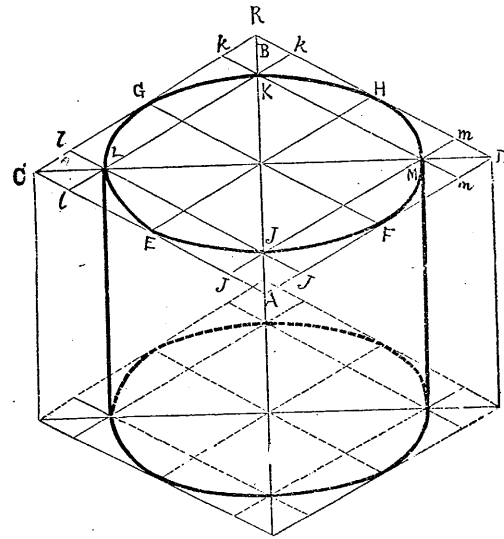

乙

圖七十三第

明治十五年十一月十二日出版  
同廿二年十一月十六日出版  
同同同

著者

福井縣士族

平瀨作五郎

岐阜縣美濃國厚見郡  
今泉村太田町三番地

東京府士族

中島精一

京橋區銀座二丁目六番地

發行兼印刷者

發兌元

賣捌

書肆

東京銀坐二丁目  
同日本橋區通三丁目  
同神田區表神保町  
同京橋區銀座四丁目  
大阪北久太郎町四丁目  
同備後町四丁目  
名古屋本町三丁目

中丸善近  
中博西屋邦  
柳原喜兵衛  
梅原龜吉  
川瀨代助